



## **AC POWER CONDITIONING AND UPS SYSTEMS**

Section 16.1 will address the various types of power problems at the site and suggest the type of equipment necessary to solve these problems. Section 16.2 gives an overview of the various types of UPS systems.

### **SECTION 16.1**

It is many times mistakenly believed that the Power Conditioning Transformer business is in competition with the UPS business, which is itself in competition with the Generator Set business. This is not true as will be shown. There are many applications where more than one of the above types of equipment is needed. In fact, many times all of the above equipment is needed to properly solve the customer's power problems.

This section does not specifically address when a Generator Set is also needed. A Generator Set, of course, brings many potential advantages to the site that a UPS alone does not bring. A few of the more obvious are:

**\*Backup from extended power outages**

Energy can be stored less expensively in diesel fuel or natural gas than it can in batteries. Usually for any given power capacity from 1 KW to many thousands of KW, if ride through times of greater than 30 minutes are desired, it is less expensive to purchase a 30 minute battery and a Gen Set. As an example, the cost savings in batteries alone in dropping from a 3 hour battery to a 30 minute battery will more than pay for a Generator Set of equal power capacity. Savings are also accomplished in the UPS because a smaller rectifier can be provided.

**\*Backup more of the total operation**

**\*Consider peak load shedding**

The table in Figure 1 below details the various types of power outages for which various regulation, isolation or UPS systems may be considered. The Table also shows the typical frequency of outage occurrence.

**Figure 1**

**CATEGORY OF AC POWER DISTURBANCES**

TYPE	VOTLAGE DEVIATION	DURATION	DISTURBANCES PER MONTH	CORRECTION NEEDED
VOLTAGE SAG OR SURGE	80-110%	1 SEC	12-20	REGULATION TRANSFORMER
BROWN OUT	80-100%	EXTENDED	?	REGULATION TRANSFORMER
TRANSIENT	400-500%	200 MICRO SEC.	50-70	ISOLATION TRANSFORMER
OUTAGE	<80%	4 MS (1/4 CYCLE)	0.5-2	UPS

**Figure 2**

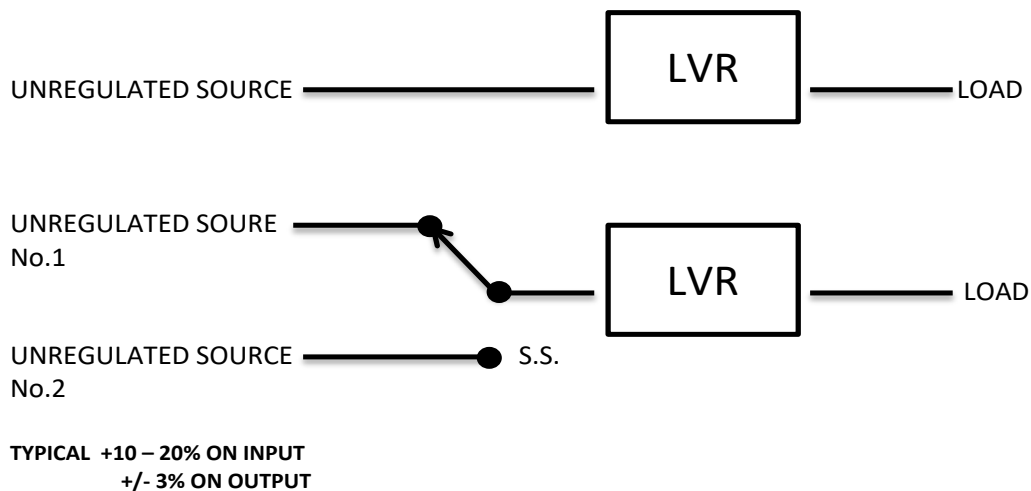

If noise on the line is the problem, an isolation transformer will be needed. Various

configurations are available from simple isolated windings to single, double and triple shielded isolated windings. Again, a static switch can be used to select between two sources for uninterrupted clean power to the load as long as one of the sources is available.

**Figure 3**

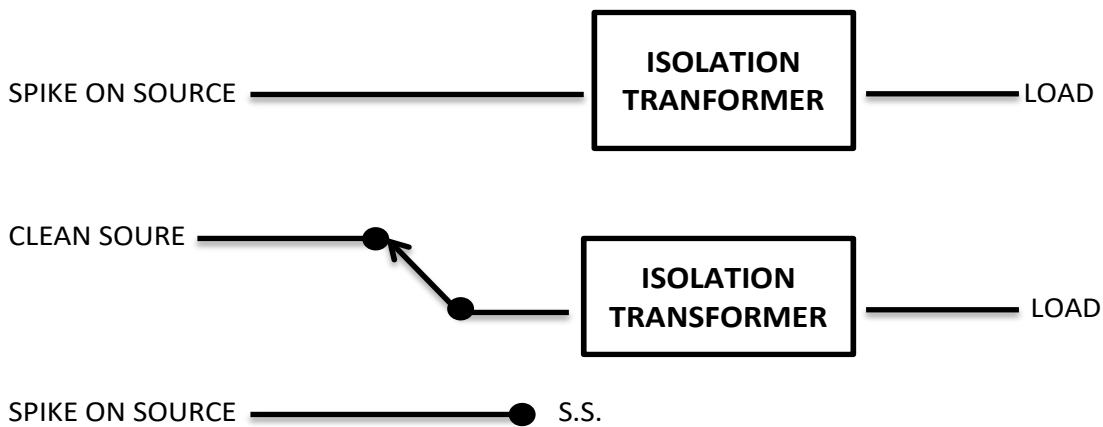

**TYPICAL 140 db COMMON MODE  
40 db TRANSVERSE MODE @ 6000HZ**

In situations where the power source has both regulation and noise problems, a device combining the qualities of both regulation and isolation is needed. This device is normally referred to as a “power conditioner”. See Figure 4 below.

**Figure 4**

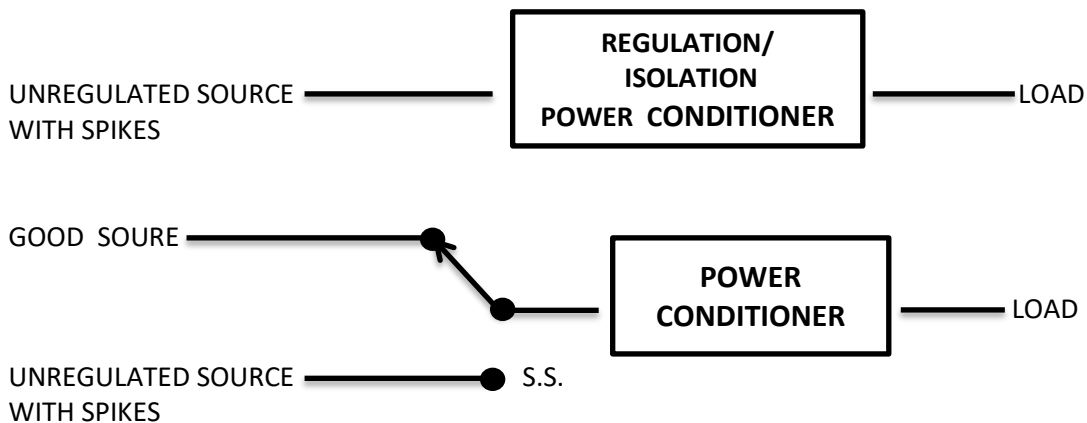

All of the above systems will provide the desired power to the load provided at least one of

the power sources is available. In the event the load needs to be backed up for a period of time when a normal utility source is not available, a UPS will be required.

The typical operation for an “on line” UPS is for it to power the load continuously through its static switch. The UPS will operate phase locked to the alternate source and track it to  $60 \text{ Hz} \pm 1 \text{ Hz}$ . In the event the UPS becomes overloaded or malfunctions, the static switch will transfer the load to the alternate source without interruption. In the event the alternate source power needs any type of conditioning to handle the load, that type of conditioning must be provided in the alternate source leg. See Figure 5 below.

**Figure 5**  
**WHEN BACKUP POWER IS NEEDED**

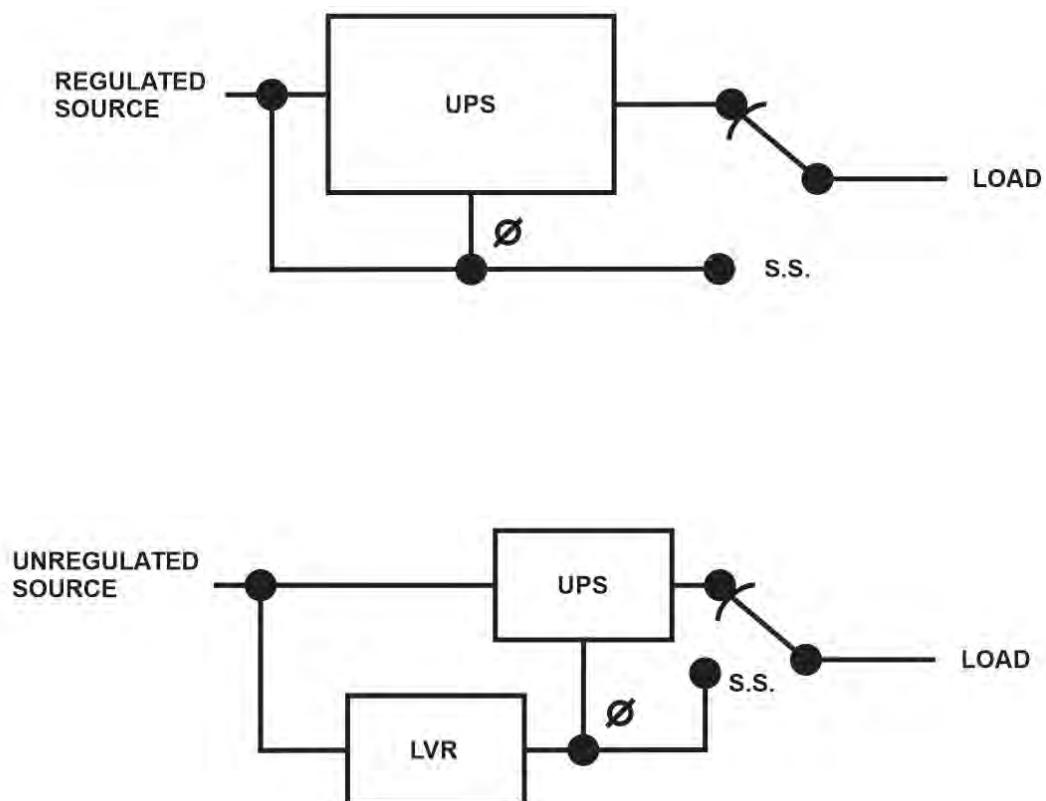

Either system in Figure 5 would provide clean no break power to the load for the ride through time of the batteries, unless the UPS were to malfunction simultaneously with the utility source. In the event additional assurance is needed, additional UPS systems can be cascaded as shown in Figure 6 below.

Figure 6

## REDUNDANT UPS

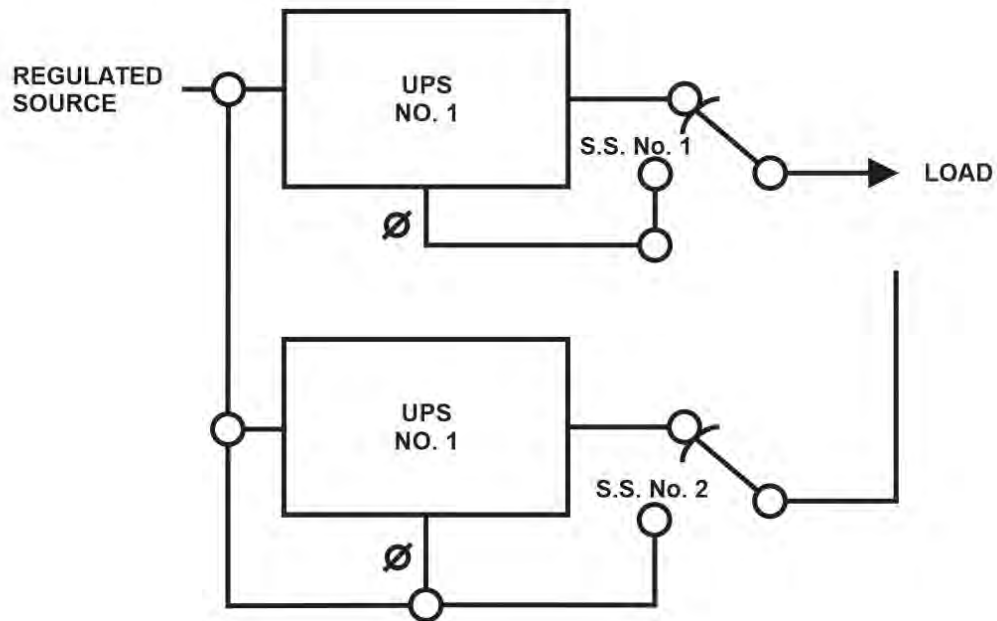

Various types of inverter technologies are available. However, the bottom line is that good reliable systems are available in each type. If a large percentage of the total UPS load is inductive, the manufacturer should be notified as this may change the amount of filtering needed. This change in filter size may cause a corresponding change in cabinet size and price.

Figure 7

## TYPES OF INVERTER TECHNOLOGY

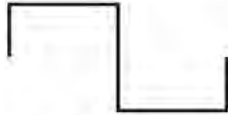
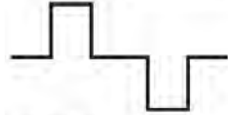
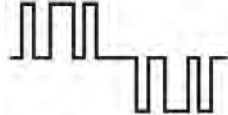
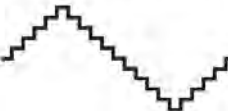
TYPE	INVERTER OUTPUT WAVEFORM	FILTER
FERRORESONANT		LARGE LC FILTER
QUASI-SQUAREWAVE		LARGE LC FILTER
PWM		MODERATE LC FILTER
SYNTHESIZED WAVEFORM		SMALL LC FILTER

### SECTION 16.2

The basic types of UPS systems available are “on line” (the inverter is the primary source) and “standby” (the inverter is the standby or alternate source).

**Figure 8**  
**TYPES OF UPS**

- ON LINE
- STANDBY
  - (Hot Idle with Electro Mechanical Switch)
  - (Hot idle with Static Switch)
  - (Hot idle into Tri Port)

The difference in the types of systems are depicted in Figures 9 and 10. The primary hardware difference is that the battery charger in the “on line” system must be sized to power a fully loaded inverter plus recharge a discharged battery. The charger in a standby system can be much smaller because it only provides idling power to the inverter and recharges the battery.

Attention should be given to the type of maintenance bypass (MBP) switch used as well. First, the MBP switch should be a make-before-break device. Usually a 4 pole, 2 position

switch is employed. This provides isolation to perform maintenance on the S.S. but does not allow for actual S.S. testing under load, after repair prior to powering the system load.

Another thing to watch out for is the phase lock indication on the UPS. Because the MBP switch is a manual, make-before-break device you would not want to throw it unless the two sources were in phase. We strongly recommend a "phase locked" lamp instead of an "out of phase" lamp. I have a three fingered friend who will testify that with an "out of phase" lamp it is difficult to tell the difference between a phase locked condition when switching the MBP is safe, and an out of phase condition "with a burned out lamp", where switching the MBP can be very dangerous.

Figure 9

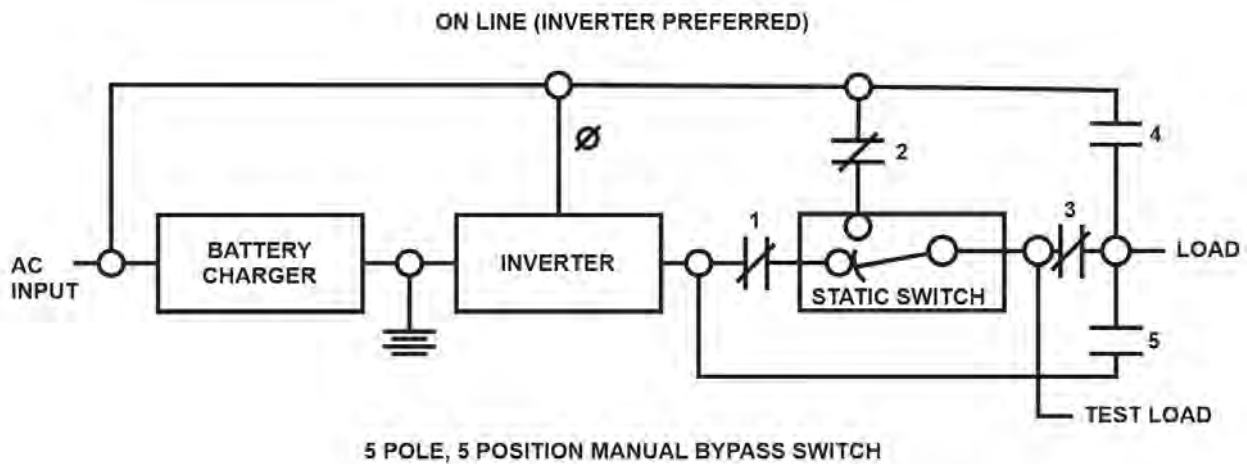

MODE	SWITCH POSITION				
	1	2	3	4	5
ALTERNATE SOURCE POWER LOAD (S.S. TEST)	x	x		x	
ALTERNATE SOURCE POWER LOAD (S.S. ISOLATED)				x	
INVERTER POWER LOAD THRU S.S. (NORMAL)	x	x	x		
INVERTER POWER LOAD (S.S. ISOLATED)					x
INVERTER POWER LOAD (S.S. TEST)	x	x			x

Figure 10

## STANDBY UPS

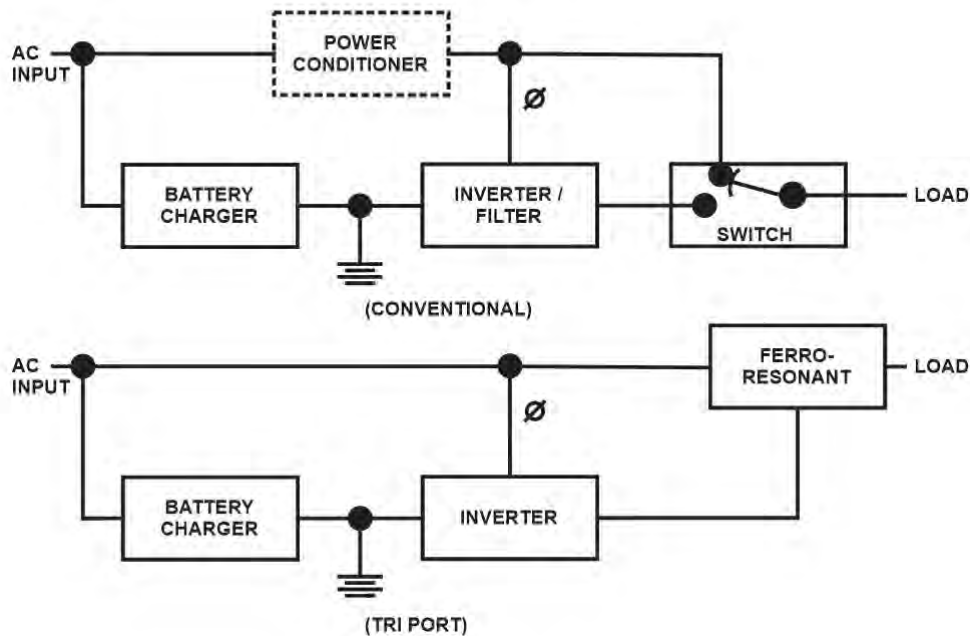

The standby system is less expensive to purchase but it makes two potentially serious compromises.

First, if the primary utility source is in a brown out condition, the load will be powered by the UPS as long as the battery lasts. However, because the charger is too small to power the fully loaded inverter, the UPS will discharge the battery and then shut down, dropping the load.

In an on-line system, the output of the charger might have lost regulation if a utility brown out existed, but it would have continued to power the loaded UPS without discharging the battery.

Second, if the frequency of the primary utility source deviates outside its preset tolerances (usually  $60 \text{ Hz} \pm 1 \text{ Hz}$ ) or changes at a slew rate greater than specified (usually 1 cycle/sec), the standby UPS will want to pick up the load but will no longer be phase locked to the primary source, thus making the no break transfer impossible.

A major consideration in sizing the UPS is: Does it have to be of sufficient capacity to handle all inrushes and fault clearing? Many times it is decided the UPS will handle all running loads but the S.S. will bypass to the alternate source for major inrushes and fault clearing. One needs to be aware that this decision, while reducing the size (therefore cost) of the UPS, also results in a system which will drop the load if these inrushes or faults occur when the alternate source is not available.



**Figure 11**

**FUSE COORDINATION**

- **IS IT DESIRED THAT THE UPS OR ALTERNATE SOURCE WILL HANDLE STARTUP INRUSHES?**
- **IS IT DESIRED THAT THE UPS OR ALTERNATE SOURCE WILL CLEAR LOAD BREAKERS OR FUSES?**