



Industrial 60 to 300KVA UPS

Professional Series (ProUPS) Uninterruptible Power Supply

- True On-line Technology for Maximum Power Protection
- Input Power Factor Correction Reduces Power Consumption Conserving Energy
- Input THD Less Than 4%
- True Double Conversion Design for Total Load Isolation and Protection
- Full Load Rated No-Break Dual Solid-State Static Switch
- Reliable and Robust Design Providing a 20-year Design Life
- Full Input / Output Isolation, Copper Wound Transformers
- LCD Monitoring Panel with Power Flow Diagram
- Dual Input for Optimal Load Protection
- Ethernet RJ45 Communications Port
- Form "C" Interface Contacts
- Generator Compatible Rectifier Input
- Built to Meet UL1778, NEMA, NEC, ANSI and FCC requirements



60-100KVA Model

OPTIONS

- ⇒ Multiple Voltage Inputs/Outputs Available
- ⇒ 50Hz/60Hz Models
- ⇒ External Maintenance Bypass Switch
- ⇒ Air Filtration and Conformal Coating
- ⇒ Circuit Breaker Status Panel
- ⇒ Emergency Power Off / Shunt Trip
- ⇒ Lockable Breakers
- ⇒ Various Battery Types and Runtimes
- ⇒ Bypass Isolation Transformer
- ⇒ Customizable Designs for Unique Applications

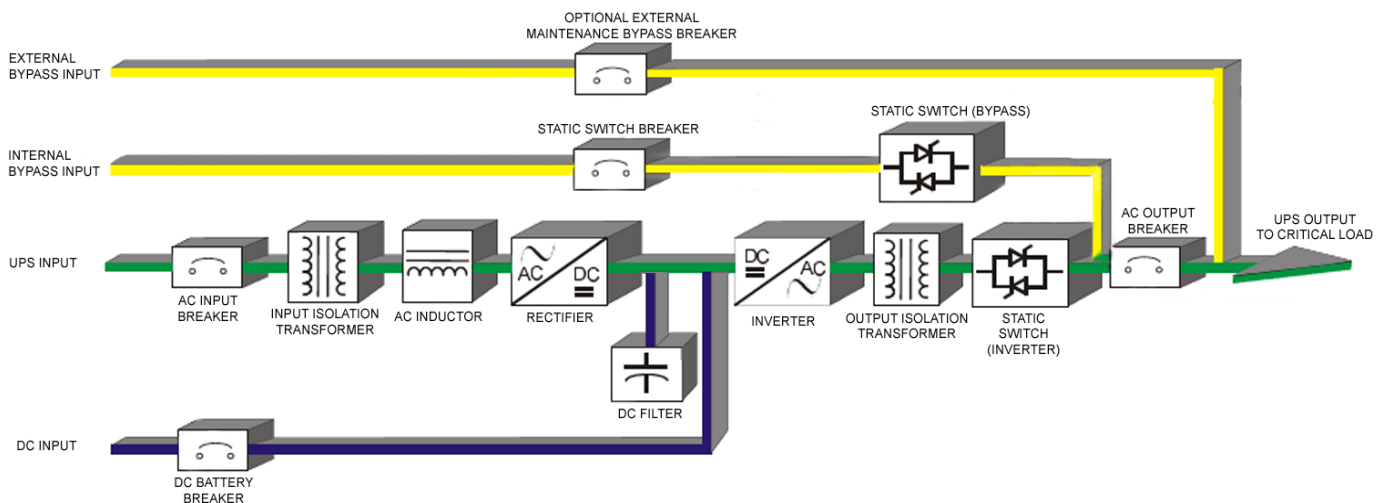



Industrial 60 to 300KVA UPS

Technical Specifications																
Model	60kva		80kva		100kva		120kva		150kva		200kva		250kva		300kva	
Input Voltage ² (3 Ph)	208	480	208	480	208	480	208	480	208	480	N/A	480	N/A	480	N/A	480
Nom. Current (Amps)	186.7	80.9	248.9	107.9	311.3	134.9	373.5	161.8	466.9	202.3	N/A	269.7	N/A	337.2	N/A	433.5
Max Current (Amps)	200.1	86.7	266.8	115.6	333.5	144.5	400.1	173.4	100	216.7	N/A	289.5	N/A	361.3	N/A	463.7
Input Distortion	<4% Total Harmonic Distortion @ full load															
Input Power Factor	Typically 1.0 P.F. @ full load															
Input Frequency ¹	50/60Hz ± 6%															
AC Output Three-Phase																
Output Voltage VAC ²	208	480	208	480	208	480	208	480	208	480	N/A	480	N/A	480	N/A	480
Frequency ¹ (Hz)	60Hz		60Hz		60Hz		60Hz		60Hz		60Hz		60Hz		60Hz	
Full Load (Amps)	166.8	72.3	222.3	96.3	277.9	120.4	333.5	144.5	416.9	180.6	N/A	240.8	N/A	301.1	N/A	361.3
DC Link																
Nominal DC Voltage ²	240		240		480		480		480		480		480		480	
DC Watts (Full Load)	52,800		70,400		88,000		105,300		132,000		176,000		220,000		264,000	
DC Amps (Full Load)	220		293.3		183.3		219.4		275		325.9		407.4		488.9	
Max DC Amps	251.4		335.2		209.5		250.7		314.3		419		523.8		628.6	
End of Discharge	210VDC		210VDC		420VDC		420VDC		420VDC		420VDC		420VDC		420VDC	
Number of Cells	120		120		240		240		240		240		240		240	
VDC Flt/Eq. Range	200 to 300		200 to 300		400 to 430		530 to 600		530 to 600		530 to 600		530 to 600		530 to 600	
Ripple (DC Filtering)	<2% RMS															
Efficiency																
DC to AC (%)	92		92		92		92		92		92		92		92	
AC to AC (%)	88		88		88		88		88		88		88		88	
BTU/Hr.	19,653		26,204		32,755		39,306		49,132		65,510		81,888		98,265	
Mechanical																
Size W x D x H (in)	81x34x65		81x34x65		81x34x65		81x34x65		112.5x34x65		112.5x34x65		112.5x34x65		112.5x34x65	
Weight (lbs)	3,380		3,590		3,760		4,130		4,360		4,640		4,800		5,200	

Input

Voltage: 3 Phase, 3 or 4-wire plus Gnd
 Voltage Range: +10%, -15%
 Rect. Freq. Range: ±5Hz
 Bypass Tracking: ±1.5Hz
 Regulation: ±1% from 0 to 100% load
 Power Factor: .99 P.F. at full rated load
 Walk-In: 10 seconds to full load
 Input THD: Typically less than 4%
 Frequency: 50Hz or 60Hz ±6%
 Surge Protection: ANSI C62.41

Environmental

Ambient Temperature: 0°C to 40°C (45°C capable)
 Relative Humidity: Up to 95% non-condensing
 Acoustical Noise: <65dB (A) scale @ 1 meter
 Altitude: 5,000 Ft without de-rating
 Storage Temperature: -20°C to 70°C

Note:

- Specifications shown reflect standard 60Hz UPS models. Models of 50Hz, 400Hz, or other frequencies available
- Other input/output/DC link voltage configurations may be available by contacting the factory.
- All models are available as stand alone DC to AC inverters and frequency converters.
- All data is subject to change without notice.

Output

Voltage: 3Ph or 1PH - 2, 3 or 4-wire + Gnd
 Regulation: ±2% from 0-100% balanced load
 ±3% for 100% unbalanced load
 Output THD: <3% linear, <5% nonlinear load
 Voltage Adj: ±5%
 Overload: 120% for 15 min, 150% for 1 min,
 Bypass- 1000% for 1 sec
 Slew Rate: 1Hz per second (adjustable)
 Frequency: ± 0.01% free running
 Fault Clearing: 160% P-P for 10 cycles
 400% P-N for 10 cycles

General Information

Cable Entry: Top or Bottom
 Ventilation: Forced Air N+1
 Paint: Light Gray
 Cabinet: Seismic Zone 4 Rated